

HAUL-ALL EQUIPMENT LTD.		NO.	REVISION	DCO NO DATE
PART NUMBER	GFL3	DRAWN BY PS-PS	1	RELEASED TO PRODUCTION.
NAME	3YD FRONT LOAD/UNLOAD BIN-TOPPER	SCALE 1/16	2	X X X
MATERIAL	AS SHOWN	FINISH NONE	3	X X X
				PS 22 APR 2015

- ALL DIMENSIONS TO BE IN INCHES UNLESS OTHERWISE NOTED.
- ALL DIMENSIONS TO BE $\pm 1/32$ " UNLESS OTHERWISE NOTED.
- ANGULAR TOLERANCES: FORMED: $\pm 1^\circ$; MACHINED $\pm 0.5^\circ$

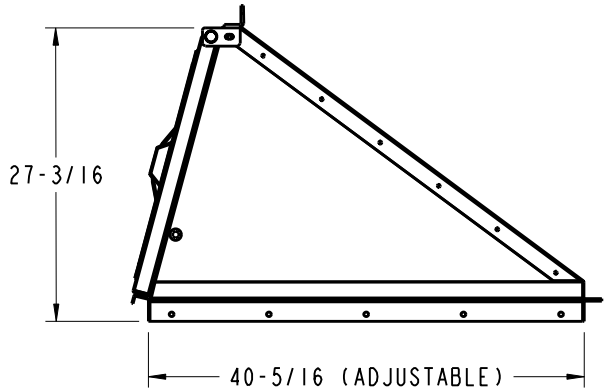
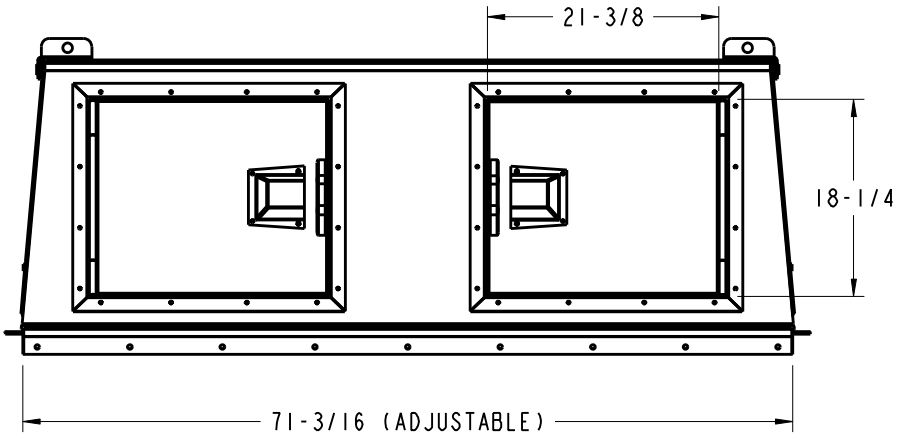
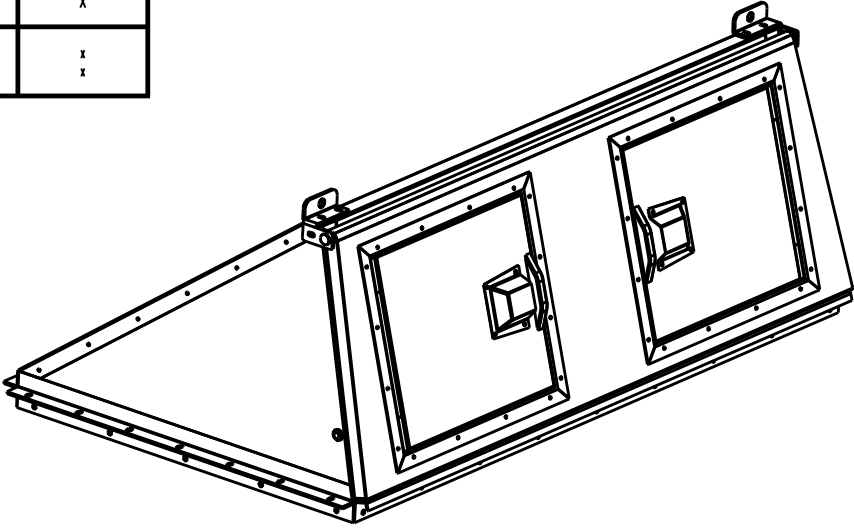
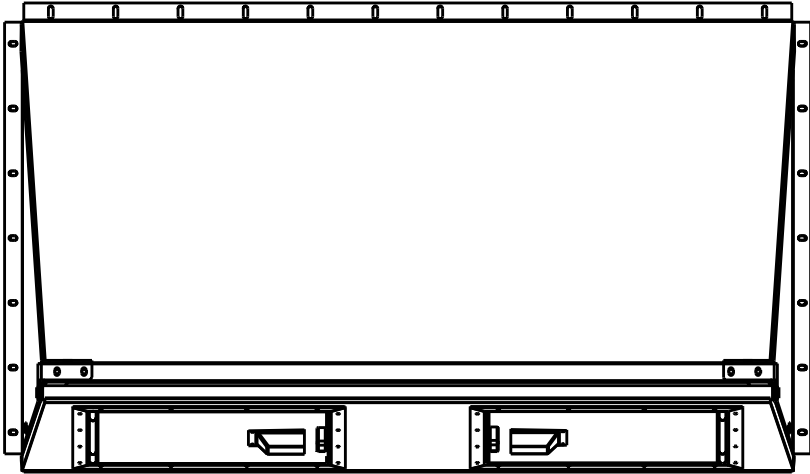

HAUL-ALL EQUIPMENT LTD.		NO.	REVISION	DCO NO DATE
PART NUMBER	GFL4	DRAWN BY PS-PS	1	RELEASED TO PRODUCTION.
				D2591 PS 21 APR 2015
NAME	4YD FRONT LOAD/UNLOAD BIN-TOPPER		2	X X X
MATERIAL	AS SHOWN	SCALE FINISH	3	X X X
		3/32 NONE		X X

- ALL DIMENSIONS TO BE IN INCHES UNLESS OTHERWISE NOTED.
- ALL DIMENSIONS TO BE $\pm 1/32"$ UNLESS OTHERWISE NOTED.
- ANGULAR TOLERANCES: FORMED: $\pm 1^\circ$; MACHINED $\pm 0.5^\circ$

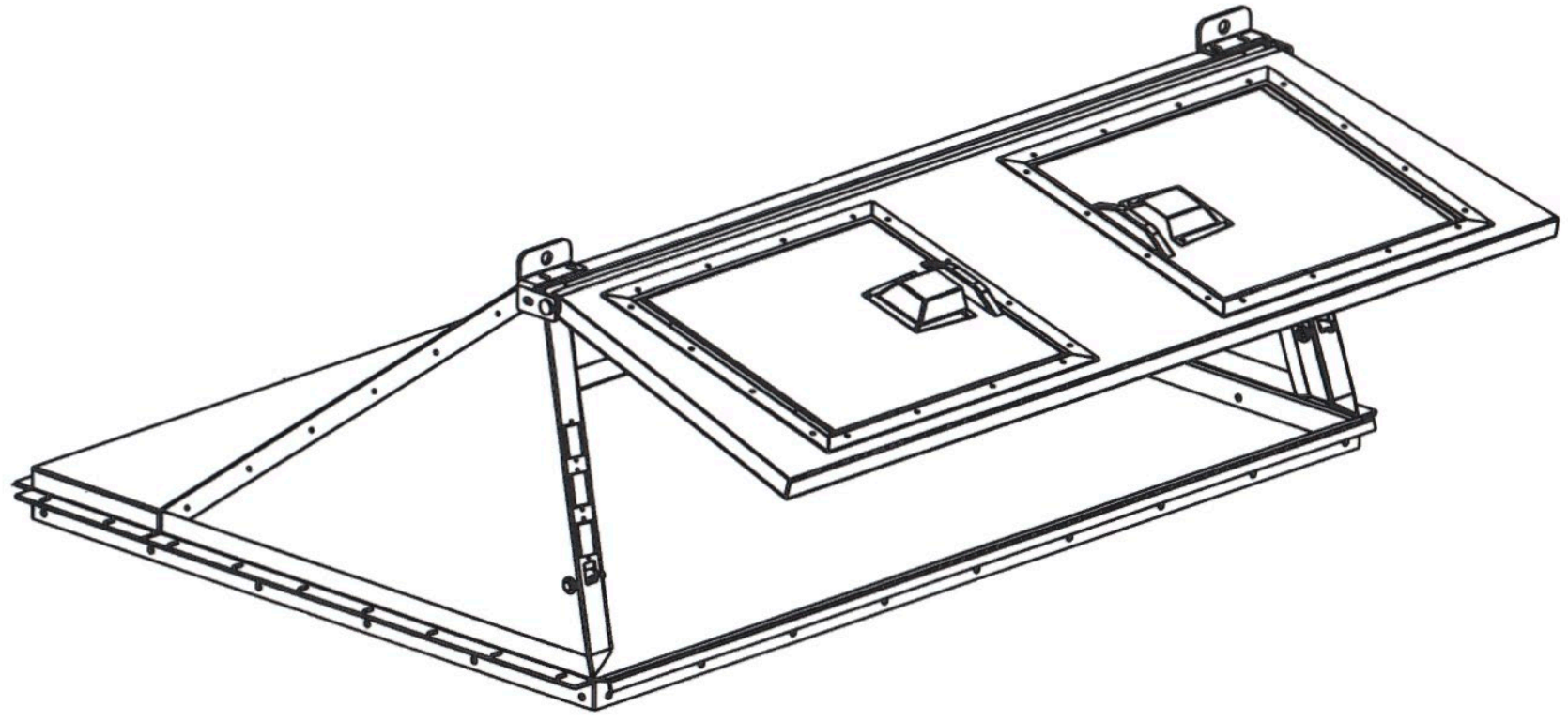

HAUL-ALL EQUIPMENT LTD.		NO.	REVISION	DCO NO DATE
PART NUMBER	GFL6	1	RELEASED TO PRODUCTION.	D2591 PS 21 APR 2015
NAME	6YD FRONT LOAD/UNLOAD BIN-TOPPER	2	X X X	X X
MATERIAL	AS SHOWN	3	X X X	X X
	SCALE 3/32			
	FINISH NONE			

- ALL DIMENSIONS TO BE IN INCHES UNLESS OTHERWISE NOTED.
- ALL DIMENSIONS TO BE $\pm 1/32"$ UNLESS OTHERWISE NOTED.
- ANGULAR TOLERANCES: FORMED: $\pm 1^\circ$; MACHINED $\pm 0.5^\circ$

