

FEATURE	DESCRIPTION	SPECIFICATION
Capacity	(2) 65 Gal Wheeled Poly-Cart	8-3/4 cu.ft. 65 US Gallons (246L)
	or (2) 95 Gal Wheeled Poly-Cart	12-3/4 cu. ft. 95 US Gallons (360L)
Construction	Housing	14 Ga. (1.9) Galvanneal Steel
	Lid	12 Ga. (2.6) Galvanneal Steel
	Floor	10 Ga. (2.6) Stainless Steel
	User Door	14 Ga. (1.9) Galvanneal Steel
	Side Hinged Unloading Door	14 Ga. (2.6 Galvanneal Steel
	Hinges and Latches	Stainless Steel
	Paint	Powder Coat
Weights	Each Hid-A-Cart Container	310lbs (140kg)
	(Optional) with Pre-Cast Mounting Pad	525lbs (240kg) 40x36x4 (1015x915x102)
	(Optional) Front Step Kit	130lbs (60kg) Kit weight only

ALL SPECIFICATIONS SUBJECT TO CHANGE WITHOUT NOTICE

BEAR PROOF RISER LATCH & HANDLE

OPTIONAL FRONT STEP c/w 2x4 CEDAR LUMBER

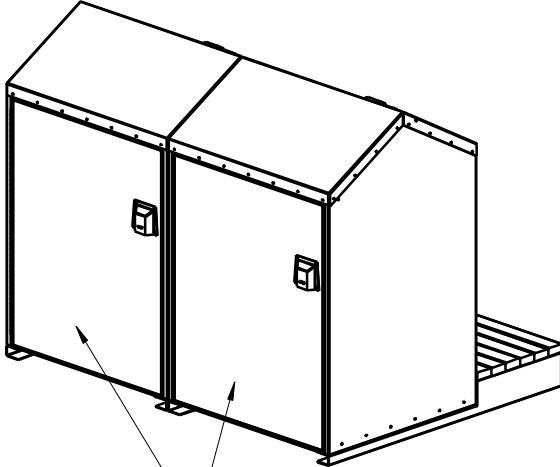
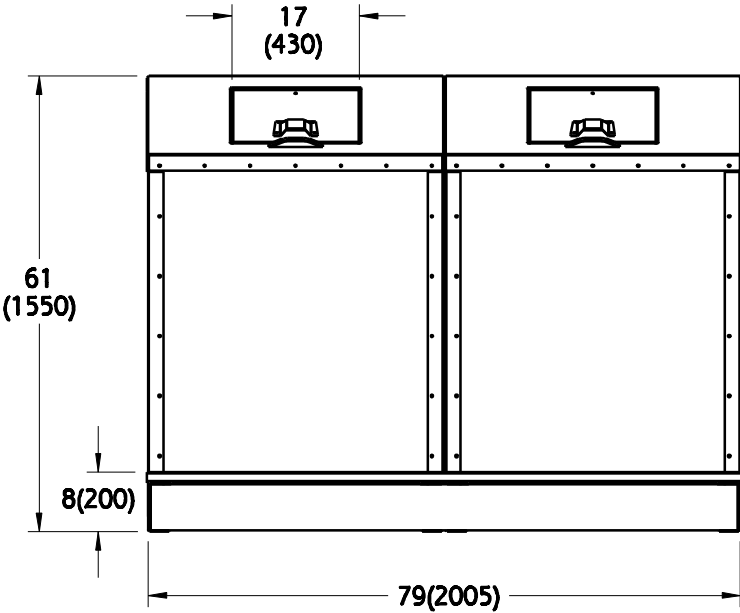
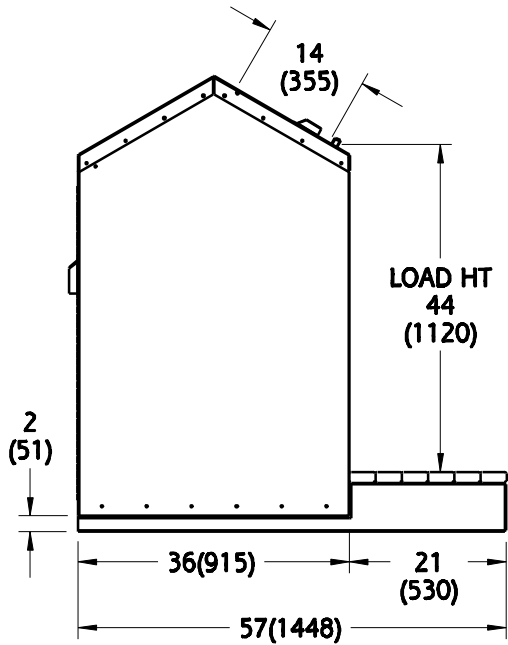
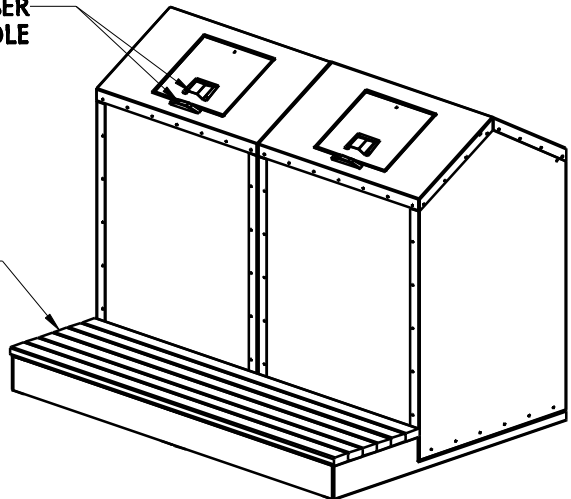

CONTAINERS FIELD ASSEMBLED WITH SUPPLIED FASTENERS

NOTE: ALL DIMENSIONS INCHES (MILLIMETERS)

TRAILER SIZE	QTY
8-1/2ft x 45ft	39
8-1/2ft x 53ft	45
B-Train 8-1/2ft x 28ft & 32ft	60
Double Decker Van 8-1/2ft x 48ft	112

HAUL-ALL EQUIPMENT LTD. reserves proprietary rights on this drawing or any part of the information contained thereon. This drawing shall be considered confidential material and is not to be used for competitive bidding nor for use in any procurements other than from Haul-All Equipment Ltd.



NAME DOUBLE HID-A-CART BP CONTAINER	
PART NUMBER SP-HC11-P	DRAWN BY PS
DATE MARCH 19, 2010	REVISION 1

